

# 200 Watt Flangeless RF Power Resistor

Data Sheet RF200-XXX Rev A



DC - 2.0 GHz.  
**HYBR-FILM™**



Model: RF200XXX



XXX = Resistance Value 1 –1000 Ω | 100 Ω Standard

**HYBR-FILM™** flangeless resistors are the highest performing RF & Microwave power film resistive products on the market today. Designed for solder attachment directly to a plated heat-sink or a plated-thru hole printed circuit board, offer the highest power and frequency rating than any other supplier. Power ratings from 30-800 watts combined with versatile industry standard configurations allow for easy design-in solutions or replacing older outdated marginal devices that may have degraded or drifted over time. Applications include Medical, Broadcast, Industrial, Commercial Wireless, Military and Space. The **P3** library of designs allows for modifications of standard designs to be made quickly and inexpensively to meet specific requirements with short delivery times. Please contact the factory for any special requirements or frequency ranges.

Electrical Performance		Mechanical Specification	
Frequency:	DC - 2.0 GHz.	Resistor:	Hybrid Blended Thick Film
Resistance Value:	1-1000Ω ±5%	Chip Material:	99.6% Beryllium Oxide
Power:	200 Watts Average	Cover:	96% Aluminum Oxide
Capacitance:	2.6 pF	I/O Tab:	99.99% Silver, .005" Thick
Power Rating:	100% @ +100°C	Ground Plane:	Platinum/Silver
		Operating Temp.:	-55°C to +150°C

Specifications subject to change without notice

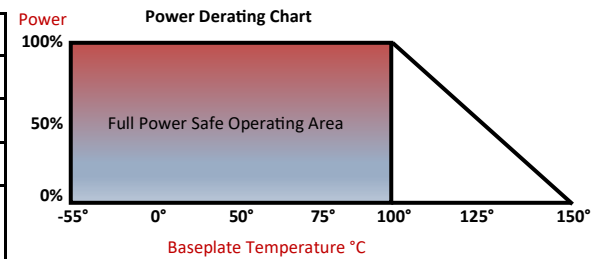

Designed to meet MIL-R-55342 and MIL-E-5400

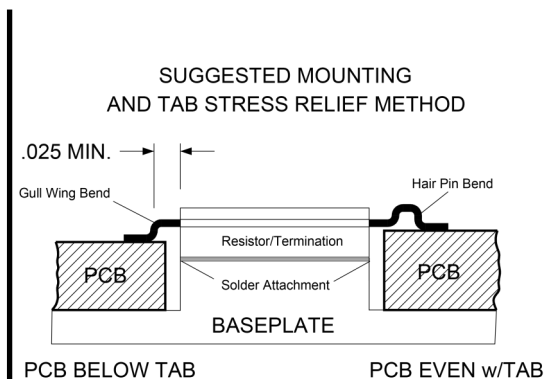
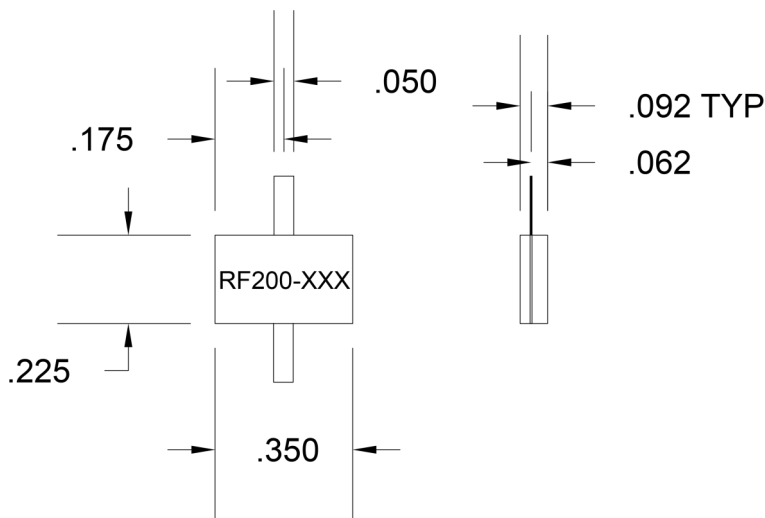

[www.preferredpowerproducts.com](http://www.preferredpowerproducts.com)

Tel: 1-772-291-2549 | [sales@preferredpowerproducts.net](mailto:sales@preferredpowerproducts.net)

STUART, FL 34997